

EcoFlow DELTA Pro 3 Smart Extra Battery

Thank you for choosing
EcoFlow portable power station

Contents

About this Manual

Overview

Appearance

LED Indicators

Getting Started

Support Your EcoFlow
DELTA Pro 3

Charge Your Smart Extra
Battery

Storage and Maintenance

Safety Instructions and
Compliances

Disclaimer

Safety Instructions

In Case of Emergency

Recycling and Disposal

Regulatory Compliance



FAQ



EcoFlow App



After-sales
Policy



Community

About this Manual

- This manual contains an introduction to this power station, and details on its operation, management, and maintenance. Please note that this manual may be updated without prior notice.
- The availability of certain accessories and features described in this manual may vary depending on your country or region.
- All images displayed in this manual are for demonstrative purposes only. Please refer to the actual product received.
- If you are reading this manual in PDF format, please note that you can access it online at <https://www.ecoflow.com/support/download/index> for a better experience and the latest updates.

Overview

EcoFlow DELTA Pro 3 Smart Extra Battery (hereinafter referred to as "the extra battery", "the battery", or "the product") is a LiFePO4 battery with a capacity of 4096Wh. It is designed to expand the battery capacity of your DELTA Pro 3 portable power station thereby providing longer-lasting power support.

Appearance

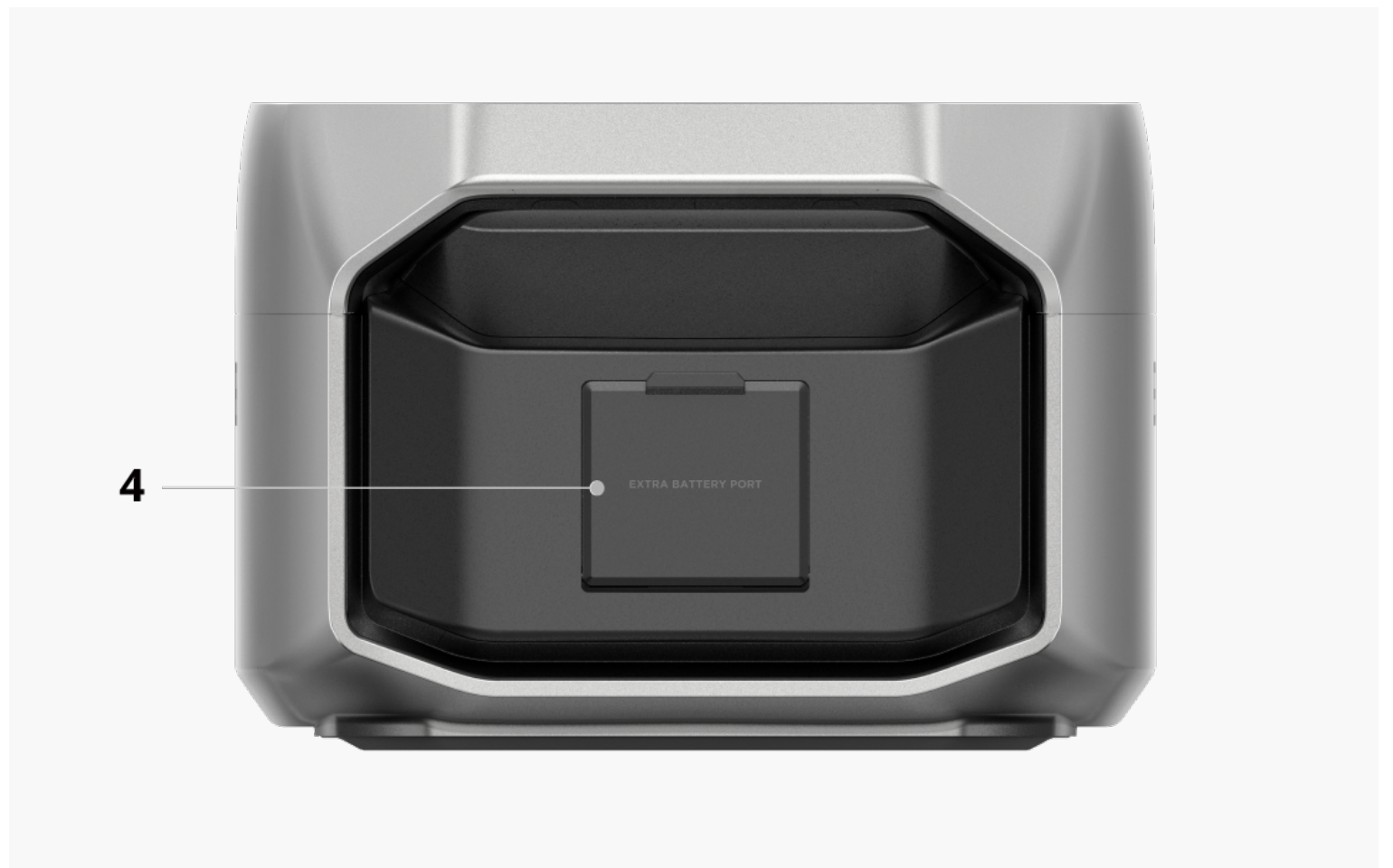

- | | |
|---|---------------------|
| 1 | Main Power Button |
| 2 | Main Power LED |
| 3 | Status LED |
| 4 | Extra Battery Port* |

* The Extra Battery Port on the extra battery is an EcoFlow proprietary port.

LED Indicators

Main Power Button

- When connected to a DELTA Pro 3 Power Station

- Power On: Long press the main power button (2 seconds) , and wait until the LED indicator lights up.
- Power Off: Long press the main power button(2 seconds) , and wait until the LED indicator turns off.
- **When disconnected from a DELTA Pro 3 Power Station**
 - Power On: Press the main power button (1 second) , and wait until the LED indicator lights up.
 - Power Off: Press the main power button (1 second) , and wait until the LED indicator turns off.

Main Power LED

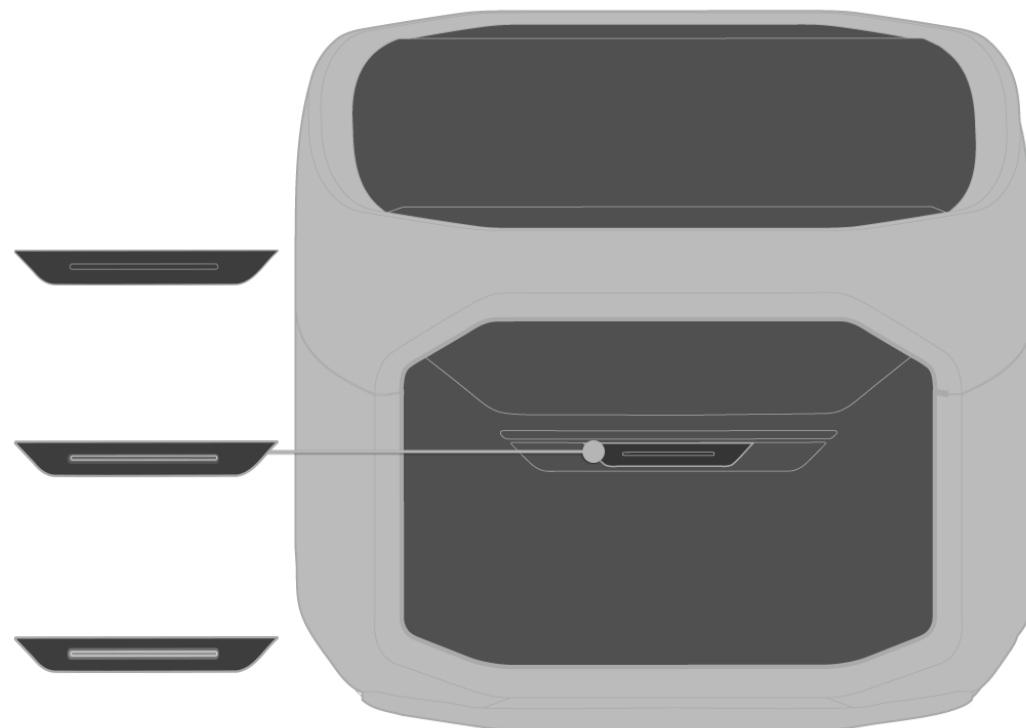

Status	Description
Off	The battery is powered off.
Breathing White	The battery is powered on and functions normally.
Flashing White	The battery is updating firmware.

Status LED

When the status LED displays an outwards running pattern, it means the extra battery is starting up.

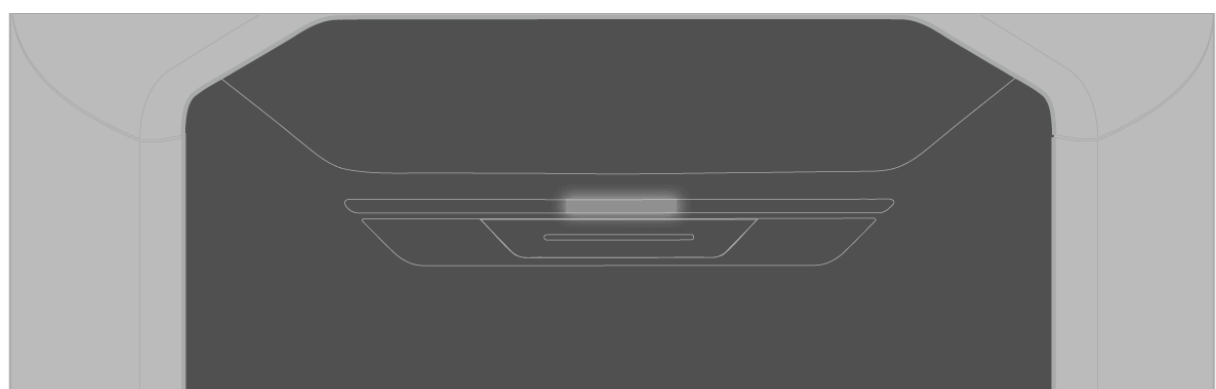

When the status LED displays an inwards running pattern, it means the extra battery is shutting down.

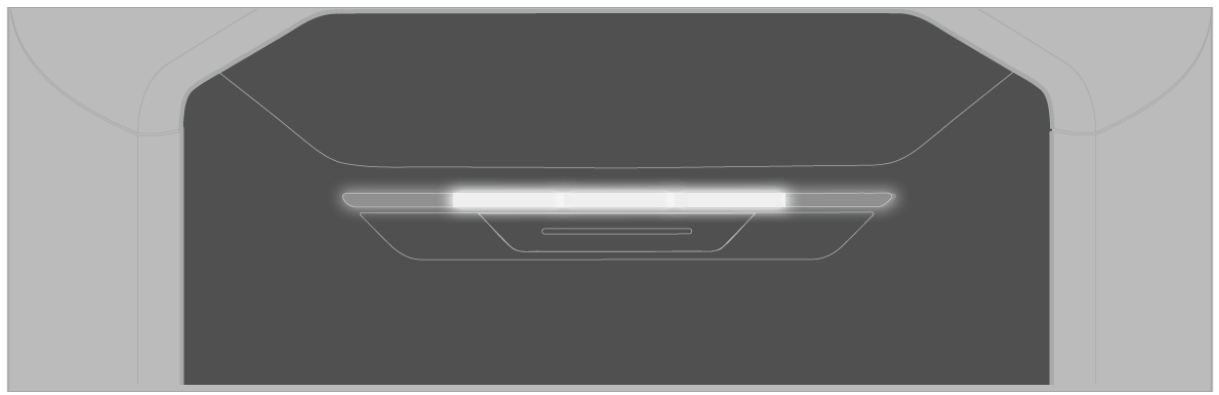

When the status LED is solid on, the amount of lighting led indicates the remaining battery level.

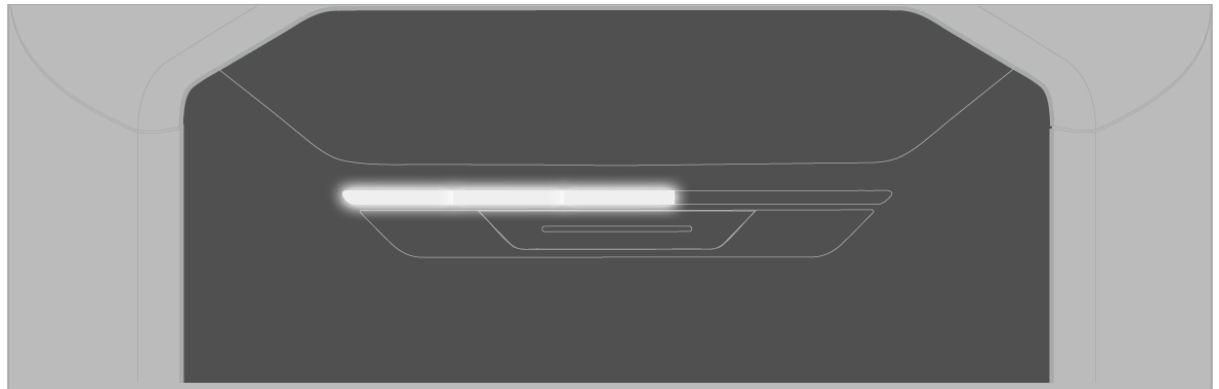

When a part of the status LED is blinking, it indicates the battery is charging.

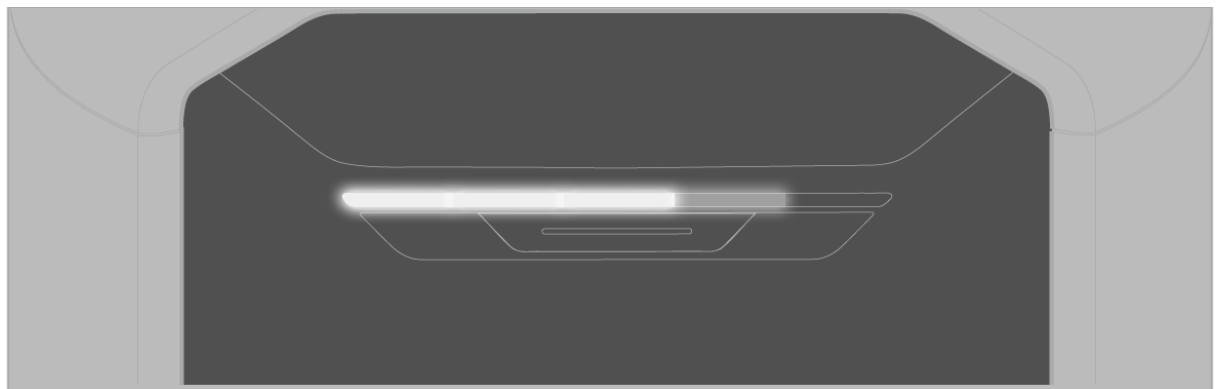

When the entire status LED is blinking, it indicates that an error has occurred.

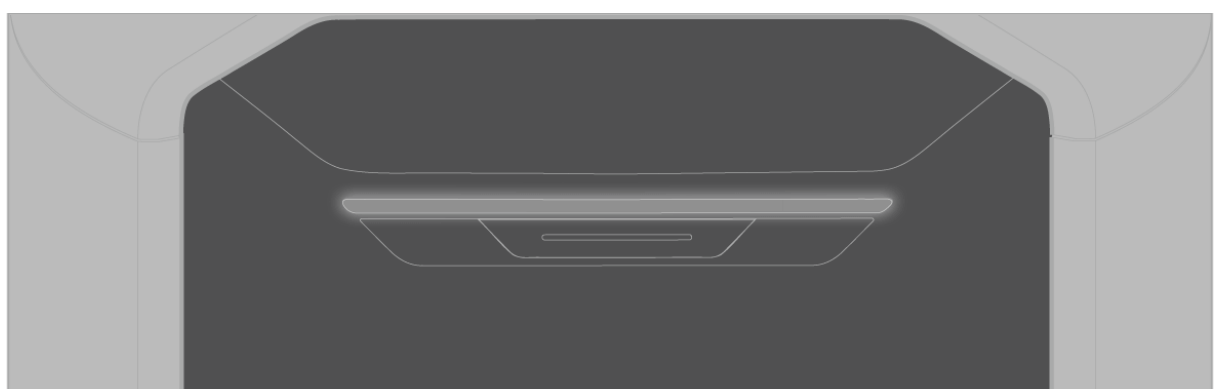

Getting Started

Support Your EcoFlow DELTA Pro 3

The extra battery can expand the power station's battery capacity, enabling it to store more electricity. Furthermore, it functions as a backup power source for loads when the power station's battery is low.

To Connect the Extra Battery

1. Connect the extra battery to the power station's Extra Battery port.
2. The extra battery is considered successfully installed once the battery icon is

displayed on the screen of the power station.

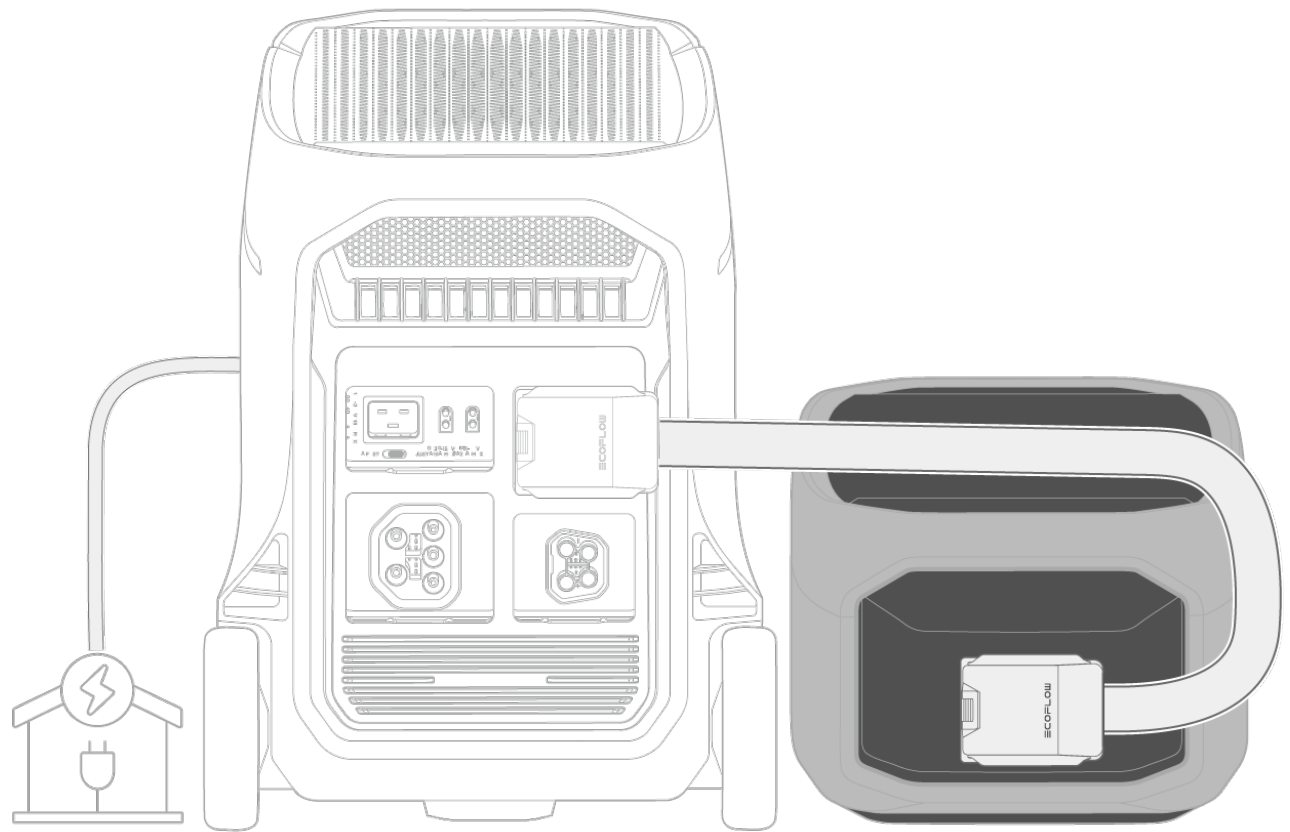

To Remove the Extra Battery

Directly remove the connection between the power station and the extra battery.

Charge Your Smart Extra Battery

Method 1: Via EcoFlow DELTA Pro 3

Connect the battery to the DELTA Pro 3 portable power station using the provided Extra Battery cable. And then connect the power station to a power source.

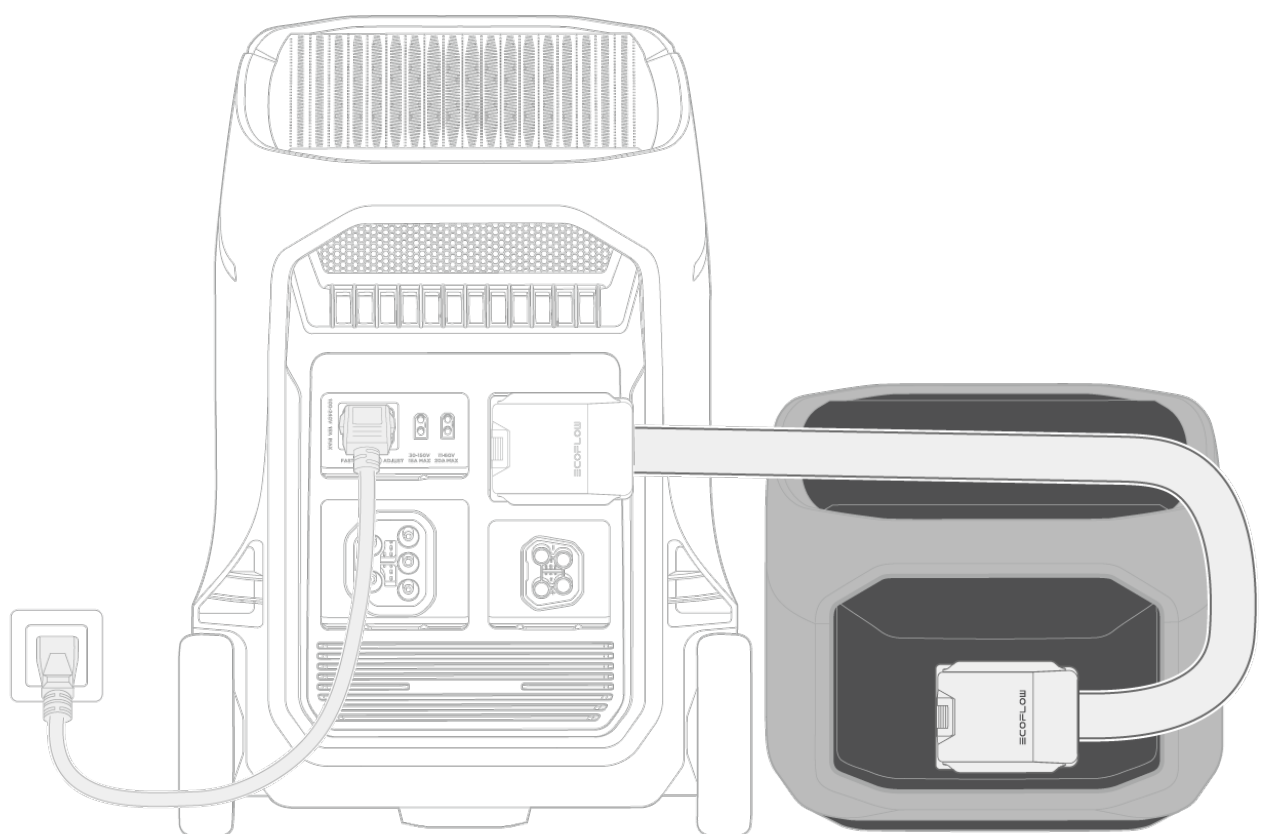

Method 2: Via EcoFlow Smart Generator

Install the DELTA Pro to Smart Generator Adapter into the battery's Extra Battery port. Then connect the extra battery to an EcoFlow smart generator's XT150 port.

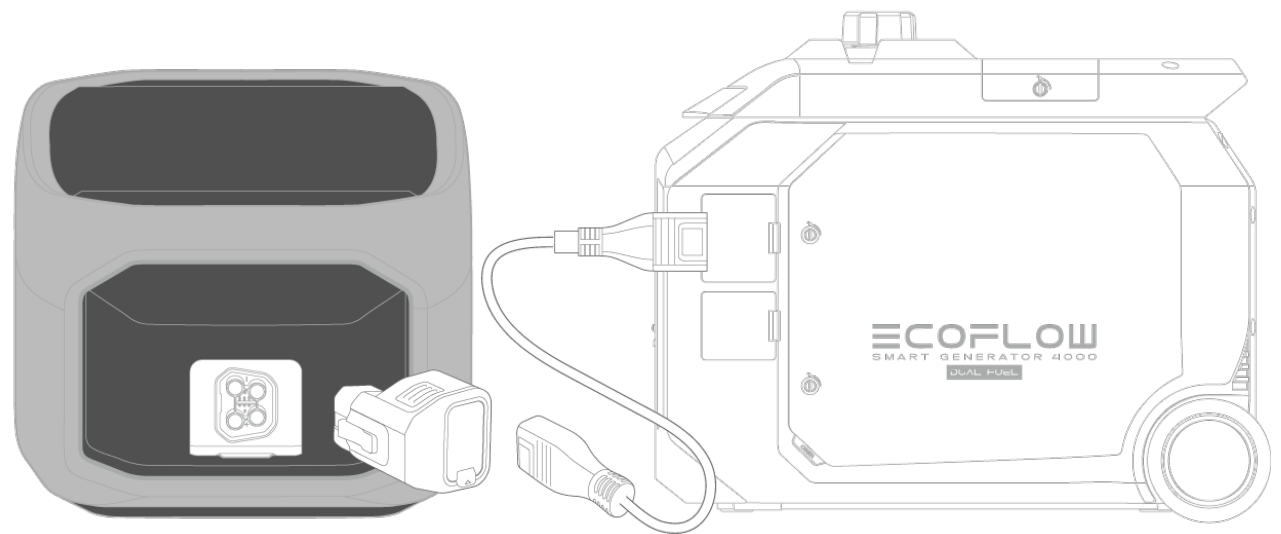

Storage and Maintenance

1. Storage

- Storage Temperature: 20°C-30°C (68°F-86°F)
- Do not store the product in places where the temperature exceeds 113°F (45°C) or falls below 14°F (-10°C).
- Store the product in a tidy, dry, and well-ventilated place.
- Keep the product away from liquids, intense heat, and sharp objects.
- For long-term storage of the product, follow these steps every 3 months to maintain battery health:
 1. Discharge the product to 0% battery level.
 2. Fully charge the product to 100% battery level.
 3. Discharge the product again to 60% battery level. Note: the product will not be covered by the warranty if it is not charged or discharged for more than 6 months.

2. Maintenance

- Cleaning Use a soft, dry cloth to wipe and clean the product.
- Maintain Battery Health Avoid leaving the product unused for extended periods of time. Charge and discharge the product every 3 months to increase its lifespan.

Safety Instructions and Compliances

Disclaimer

Please read the product document and ensure that you understand it fully before using the product. After reading this document, keep it for future reference. Improper use of this product may cause serious injury to yourself or others, or cause product damage and property loss. Once you use this product, it is deemed that you understand, approve and accept all the terms and content in this document. EcoFlow is not liable for any loss caused by the user's failure to use the product in compliance with the product document. In compliance with laws and regulations, EcoFlow reserves the right to the final interpretation of this document and all documents related to the product. This document is subject to changes (updates, revisions, or termination) without prior notice. Please visit EcoFlow's official website to obtain the latest product information: <https://www.ecoflow.com/>.

Safety Instructions

1. Do not subject this product to severe impacts, vibrations, or drops.
2. Do not carry this product onto a plane.
3. Do not use the product near a heat source, such as a fire source or a heating furnace.
4. Do not get the product wet or immerse it in any liquid. When using the product in wet environments like rainy areas or places near water, protect it with a waterproof bag.
5. Follow the environment temperature requirements specified in the product specification to use or store the product. Avoid degradation or damage to the product, or risks to personal safety due to excessively high or low temperatures.
6. Do not use the product in an environment with strong static electricity or magnetic fields.
7. Keep the product out of reach of children and pets. If the product is to be used near children, they should be closely supervised.
8. Keep the product away from fumes, smoke, steam, and dust.
9. Store the product in a tidy, dry, and well-ventilated place.
10. Do not disassemble, repair, or modify this product by yourself. For any maintenance or service, please contact EcoFlow Customer Service.
11. Always disconnect the product from all external power sources before attempting any service or maintenance.
12. To reduce risk of damage to the electric plug and cord, pull the plug rather than the cord when disconnecting the product.
13. Do not pierce the product with sharp objects.
14. Do not put fingers or hands into the product.
15. Do not insert wires or other metal objects into the product to prevent short circuits.
16. Do not use any unofficial or unrecommended components or accessories. For any replacements, please contact EcoFlow for further assistance.
17. Do not operate this product with a damaged cord or plug, or a damaged output cable.
18. Do not stack any heavy objects on the product.
19. Place the product on a stable and flat surface. Avoid damage to the device or personal injury due to the product falling or tipping over.
20. Use a soft, dry cloth to wipe and clean the product.
21. **Use in Repair Facility:** During use in a repair facility like a vehicle repair center, workshop, or any other place where repairs are conducted, do not place the product on the floor, or at a height less than 457 mm (18 inches) above the floor.

In Case of Emergency

1. In case of emergency, take precautions against electric shock before touching the product, such as wearing insulating gloves.
2. If the product gets wet, stop using it immediately and refrain from further operation or powering it on. Place the product in a secure, waterproof, and well-ventilated area, then contact EcoFlow Customer Service for assistance.
3. If the product falls into water, place it in a secure, waterproof, and well-ventilated area, and keep it away from contact until it is completely dry. The dried product should not be used again and must be properly disposed of according to local laws and regulations.
4. If the product catches fire, we recommend that you use the fire extinguishers in the following order: water or water mist, sand, fire blanket, dry powder, and finally a

carbon dioxide fire extinguisher.

5. If the product is overturned and severely damaged, wear insulating gloves to turn it off, and then place the product in an open area far from flammable materials and people., and dispose of it according to local laws and regulations.

Recycling and Disposal

1. The product with severe damage, malfunction, or depleted battery life should be properly disposed of or recycled.
2. The product contains batteries. Please dispose of the product following local laws and regulations for battery disposal and recycling. Do not dispose of it with household waste to avoid environmental pollution and safety hazards.
3. If possible, ensure the battery is completely discharged (to 0% capacity) before disposing of the product. If not, refrain from placing the battery directly into a battery recycling box. Instead, contact a professional battery recycling company for proper handling.

Regulatory Compliance

FCC Compliance Statement

This device complies with part 15 of the FCC Rules. Operation is subject to the following two conditions:

- (1) This device may not cause harmful interference, and
- (2) this device must accept any interference received, including interference that may cause undesired operation.

Any Changes or modifications not expressly approved by the party responsible for compliance could void the user's authority to operate the equipment.

Note: This equipment has been tested and found to comply with the limits for a Class B digital device, pursuant to part 15 of the FCC Rules. These limits are designed to provide reasonable protection against harmful interference in a residential installation. This equipment generates uses and can radiate radio frequency energy and, if not installed and used in accordance with the instructions, may cause harmful interference to radio communications. However, there is no guarantee that interference will not occur in a particular installation. If this equipment does cause harmful interference to radio or television reception, which can be determined by turning the equipment off and on, the user is encouraged to try to correct the interference by one or more of the following measures:

- Reorient or relocate the receiving antenna.
- Increase the separation between the equipment and receiver.
- Connect the equipment into an outlet on a circuit different from that to which the receiver is connected.
- Consult the dealer or an experienced radio/TV technician for help.

IC Compliance Statement

This device complies with Industry Canada licence-exempt RSS standard(s). Operation is subject to the following two conditions:

- (1) this device may not cause interference, and
- (2) this device must accept any interference, including interference that may cause undesired operation of the device.

This Class B digital apparatus complies with Canadian ICES-003.

Le présent appareil est conforme aux CNR d'Industrie Canada applicables aux appareils radio exempts de licence. L'exploitation est autorisée aux deux conditions suivantes:

- (1) l'appareil ne doit pas produire de brouillage, et
- (2) l'utilisateur de l'appareil doit accepter tout brouillage radioélectrique subi, même si le brouillage est susceptible d'en compromettre le fonctionnement.

Cet appareil numérique de la classe B est conforme à la norme NMB-003 du Canada.

CE

Hereby, EcoFlow Inc. declares that the equipment type battery is in compliance with Directives 2014/30/EU, 2011/65/EU(RoHS), (EU) 2015/863(RoHS), . The full text of the EU Declaration of Conformity is available at the following Internet address:

<http://www.ecoflow.com/eu/eu-compliance>

Battery Directive

Hereby, EcoFlow Inc. declares that the equipment type battery is in compliance with Regulation (EU) 2023/1542 of the European Parliament.