

# we:boost

## Installation Guide

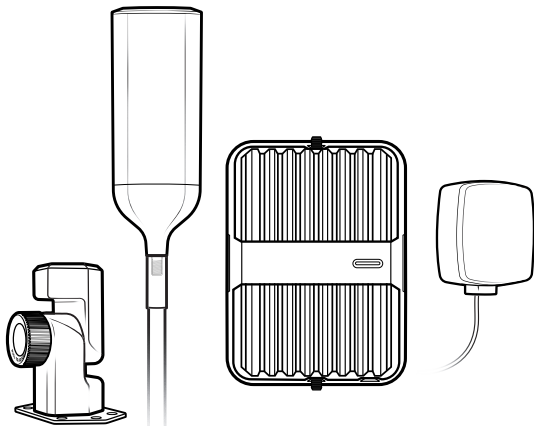

## Drive Reach RV II Cellular Signal Booster

Use the **weBoost App** to guide you through the installation. See inside page for more details.

## Download the weBoost App

Use the app to guide you through setting up a weBoost cell phone signal booster in your home, business, or vehicle. Boost every network, including 5G, right away.



# Index

Package Contents . . . . .	1
Installation Overview . . . . .	2
STEP 1 Select Mounting Location & Assemble the Outside Antenna . . . . .	4
STEP 2 Mounting the Outside Antenna with Mounting Bracket . . . . .	7
STEP 3 Route Cable into RV . . . . .	11
STEP 4 Mount the Inside Antenna . . . . .	14
STEP 5 Booster Location & Connect Coax Cables . . . . .	15
STEP 6 Connect Power Supply to Booster . . . . .	17
Hardwire Power Option . . . . .	18
Booster Light Patterns . . . . .	21
Troubleshooting . . . . .	23
Safety Guidelines . . . . .	25
Specifications . . . . .	28
Warranty . . . . .	29

## Package Contents



Drive Reach Signal  
Booster & Bracket

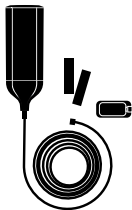

Outside Antenna,  
25 ft. Cable, Cable  
Entry Cover & Heat  
Shrink Tubes

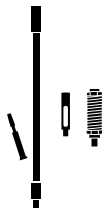

13 in. Mast Extension,  
Side-Exit Adapter,  
Spring & Thread  
Lock Pack



Inside  
Antenna



Overland Mounting  
Bracket & Mounting Hardware



AC/DC Power Supply &  
Hardware Power Supply  
with In-line Fuse Holder

# Installation Overview

NOTE: Outside antenna can be positioned horizontally when not in use. System will only function with the antenna in the upright position.

For best performance, maximize the separation between the Inside and Outside Antennas.

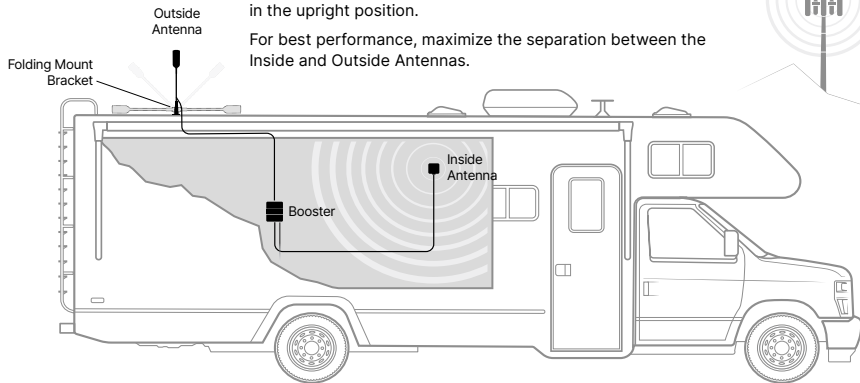

Works with Different RV Vehicle Types



## Best Outside Antenna Position

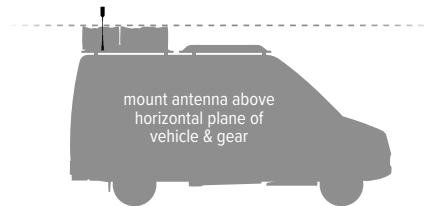

For best performance the outside antenna should be mounted above the horizontal plane of the vehicle and/or above other gear on top of the vehicle.

Pro tip: By mounting the outside antenna toward the rear of your RV, you allow the cables to create separation and thereby increase performance of the booster.

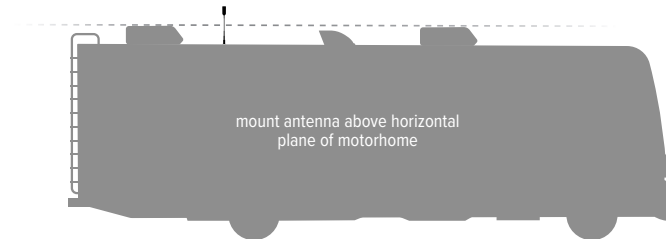

## STEP 1 Select Mounting Location & Assemble the Outside Antenna

**Determine where you want the outside antenna on your RV.** The outside antenna can be mounted to a ladder or pole, or fixed mounted to the roof or t-track.

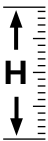
 NOTE: Refer to outside antenna maximum clearance height allowed by law. Generally, western states have a max height of 14' and eastern states have a max height of 13'6".

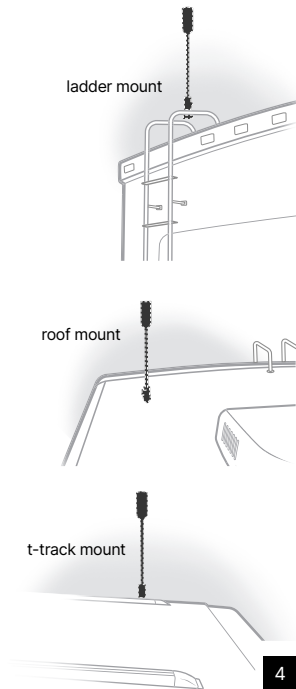

## (STEP 1 cont.)

The antenna should be mounted above gear on top of the vehicle. Once you have determined the best location for the outside antenna, **insert coax cable through the mast extension (if using), then through the side-exit adapter.**

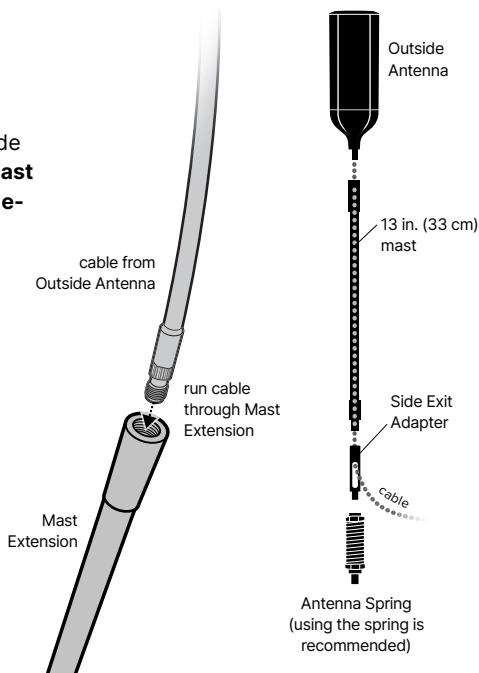



## (STEP 1 cont.)

Once the outside antenna is assembled at the correct height, **apply the thread locker precisely to thread points only**, not to the plastic body of the antenna. **Screw mast onto the antenna.**

**Connect the 25-foot cable to the outside antenna cable.** Optional heat shrink tube can be applied to the connection.

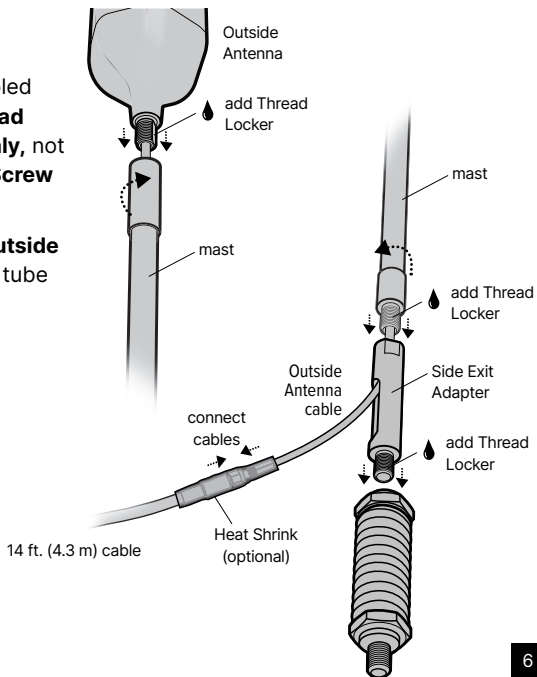

## STEP 2 Mount the Outside Antenna with Mounting Bracket

This kit includes a folding mounting bracket to secure the antenna at 90 (degree) for operation, as well as 45 (degree), 135 (degree) and horizontal for storage. This makes it easier to install the outside antenna on different types of RV vehicles. **The folding mountain bracket allows for different mounting options: Ladder mounting, Fixed roof mounting and T-track mounting.**

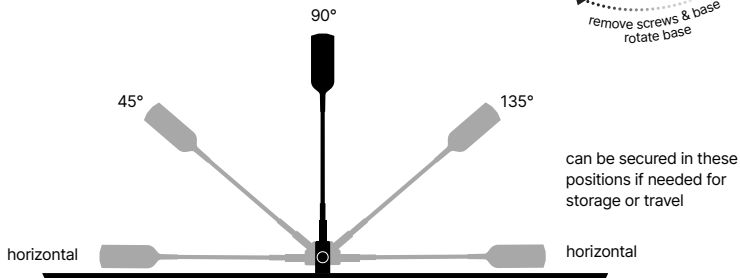
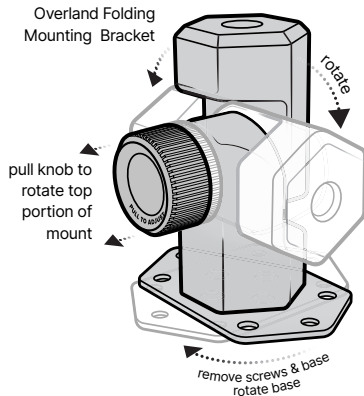

NOTE: System will only fully function with the antenna in the upright position.

(STEP 2 cont.)

## Ladder Mounting Option

**Brackets, hardware and non-slip rubber pad** are also provided for securing the **folding mounting bracket** to **1.0-1.25 inch diameter** poles, like roof rails or ladders.

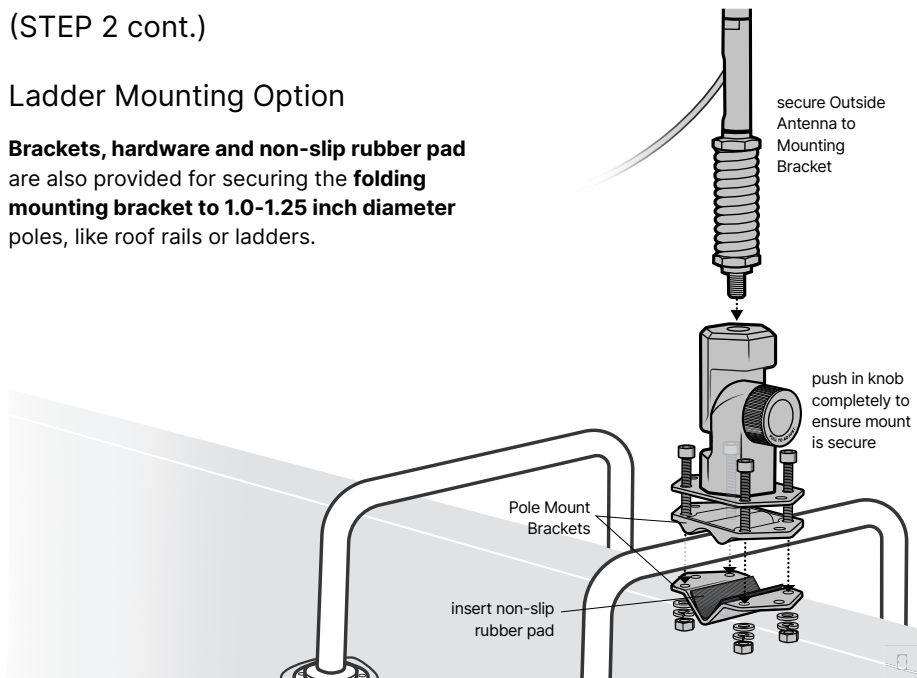

(STEP 2 cont.)

## Fixed Roof Mounting Option

The **folding mounting bracket** can also be secured to a flat roof surface as shown here. **Choose suitable fasteners** (e.g., lag screws, well nuts, sheet metal screws, toggle bolts, t-anchors) for the roof material. All roof holes & fasteners heads must be sealed with roof-compatible sealant.

### You Will Need

- Drill and drill bit
- Suitable fasteners (e.g., lag screws, well nuts, sheet metal screws, toggle bolts, t-anchors)
- Roof-compatible sealant

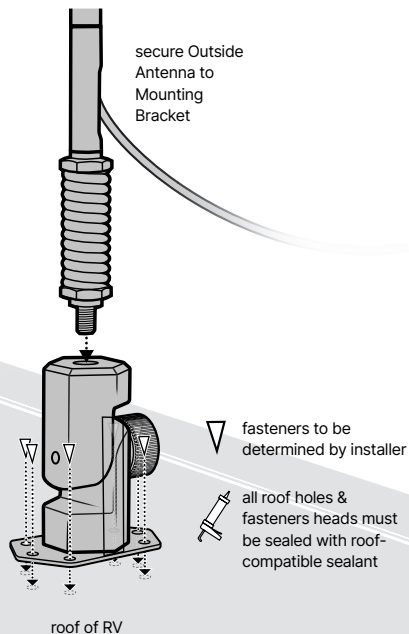

(STEP 2 cont.)

## T-Track Mounting Option

For RVs with t-tracks, the folding mounting bracket can be installed. **Use the provided t-track mounting hardware** to secure the bracket to the RV t-track, then screw in assembled outside antenna.

NOTE: Some t-tracks may not be compatible with the included hardware. If the hardware does not fit your track, you will need to provide a compatible channel nut to support your t-track.

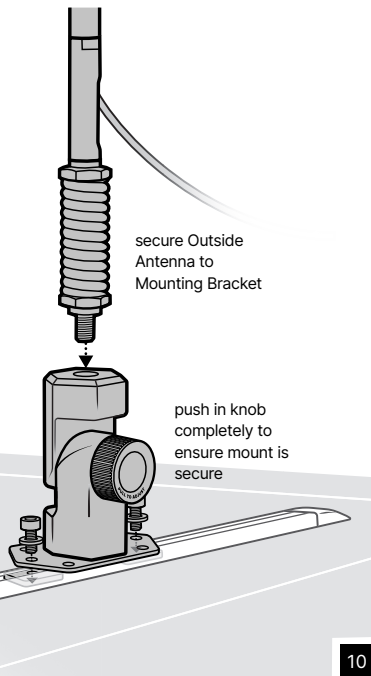

## STEP 3 Route Cable into RV

### Option 1: Using Existing Cable Entry

Once the outside antenna is mounted and secured, **route the coax cable into the RV**. There are different options to achieve this. A good time-saver would be to use an **existing junction box** or cable gland for a satellite or solar panels.

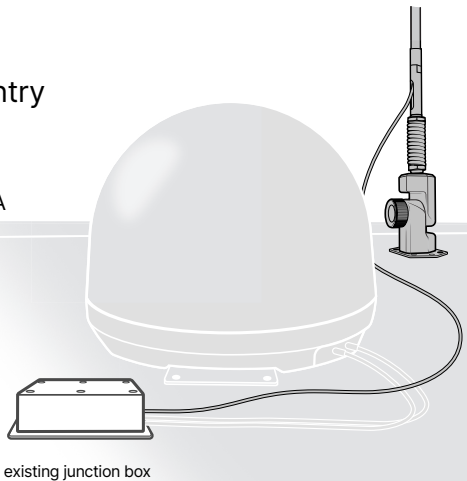

(STEP 3 cont.)

## Option 2: Using Pop-Out for Cable Entry

If your RV has a slide-out, the cable can be routed **through the rubber gasket** and into the area where the booster will be placed.

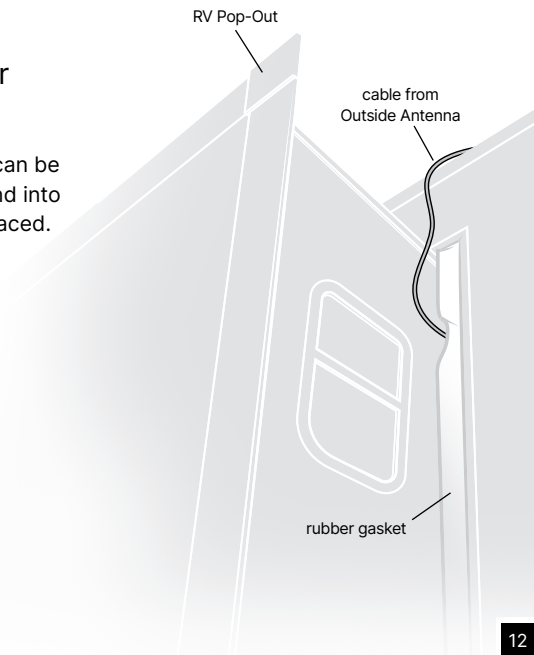

## (STEP 3 cont.)

### Option 3: Installing Cable Entry Gland

Select a suitable location on top of the RV that provides a clear path for the cable. **Drill a hole** that the cable and connector will fit snugly into. **Insert the cable into the gland** and into drilled hole as shown. **Apply roof-compatible sealant** around the hole and bottom of the gland. Press gland into place and tighten cap. Apply additional sealant around the edges.

#### You Will Need

- Drill and drill bit
- Roof sealant

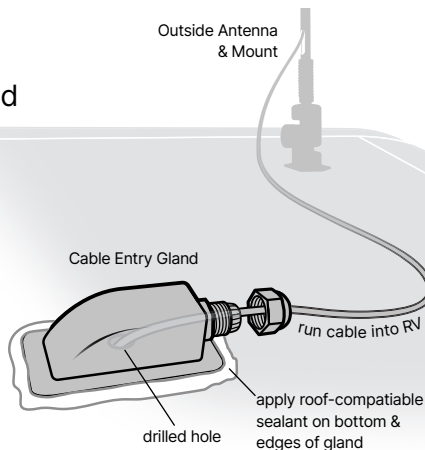

#### IMPORTANT INSTALLATION WARNING

**Safety First:** Ensure you are not drilling through any cables or power lines. Consult your RV's owner's manual for guidance.

**Seal Integrity:** Properly sealing the cable entry gland is crucial to prevent leaks and water damage.

**Professional Assistance:** Only proceed with this installation if you are comfortable with the process. If you are not confident, have it installed by a professional.



## STEP 4 Mount the Inside Antenna

**Identify a place to mount the inside antenna where a stronger signal is desired and within reach of the booster.** The antenna can be wall mounted using the provided Velcro® adhesive pad.

NOTE: Do not mount the inside antenna where an airbag will deploy.

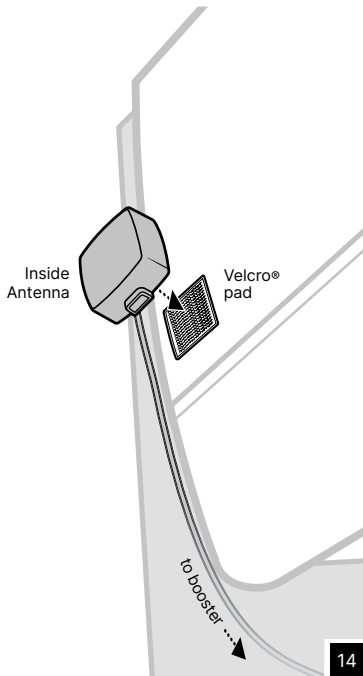

## STEP 5 Booster Location & Connect Coax Cables

**Find an accessible location** to place the booster that has good air flow. The booster includes a mounting bracket that provides different mounting options. It can be secured with Velcro® strips, screws or zip ties.

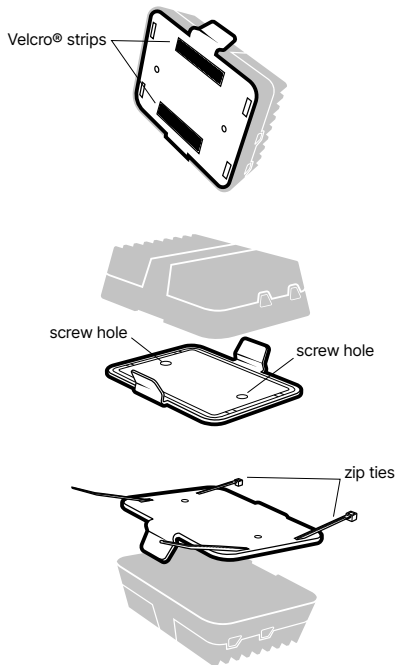

(STEP 5 cont.)

**Connect the coax cable** from the outside antenna to the port labeled the **Outside Antenna** on the booster. Then **connect the cable** from the inside antenna to the port labeled the **Inside Antenna** on the booster.

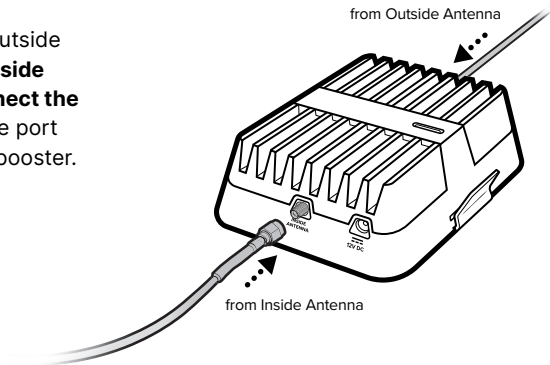

## STEP 6 Connect Power Supply to Booster

### Option 1: AC/DC Power Supply

Connect the AC/DC power supply cord to the end of the booster, labeled **12V DC**, and connect into a **12V wall plug**. There is also a hardwire power supply included that will connect directly to the RV's 12V power system. For hardwire power supply instructions see next page.

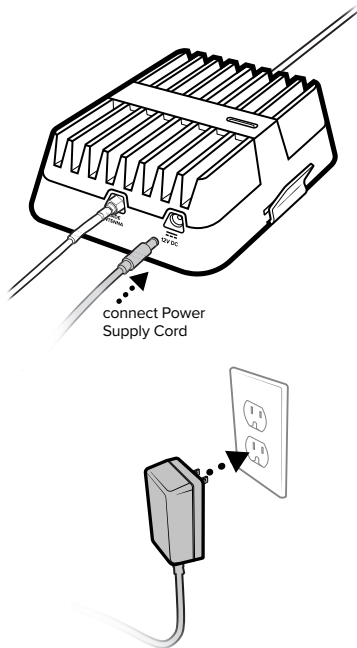

(STEP 6 cont.)

## Option 2: Hardwire Power

### You Will Need

- Fuse tap
- Cable crimper tool
- Butt connector or wire nuts
- Electrical tape

**Use the steps below as a general template for wiring the power. There are multiple options for wiring and steps will vary depending on the RV type.**

- **Locate the RV's 12V Power distribution panel.** The 12V power distribution panel is typically located near the main control panel, under the dinette seat, behind a cabinet door, or in the storage compartment. Check your RV's manual for specifics. The panel will have multiple fuses or breakers for different 12V circuits within the RV. It's often marked with labels indicating the circuits (e.g., lights, water pump).
- **Plan the Installation.** Plan cable paths from the booster to the 12V power source, ensuring there is enough cable.
- **Choose a Suitable 12V circuit.** Look for an unused or spare fuse slot in the distribution panel. This is the ideal place to add a new circuit for your booster. Alternatively, you can

## (STEP 6 cont.)

tap into an existing 12V circuit that can handle the additional load of the booster (less than 2 amps).

- **For safety, turn off the power.** Before working on the electrical system, turn off the main 12V power switch or disconnect the RV from shore power and battery to prevent electrical hazards.
- **Install the inline fuse holder.** If using an existing circuit, identify the positive (red) wire of the circuit you'll be tapping into. Cut this wire to insert the inline fuse holder. Strip about 1/2 inch of insulation from both ends of the cut wire and the fuse holder wires.
- **Connect the inline fuse holder.** Use butt connectors or wire nuts to connect one end of the inline fuse holder to the power source wire (from the distribution panel) and the other end to the wire leading to the booster. Crimp the connectors securely and cover the connections with electrical tape or heat shrink tubing. Insert the included fuse into the fuse holder.
- **Connect the Ground Wire.** Find a good grounding point near the booster unit, such as a chassis ground or the negative bus bar in the distribution panel. Connect the ground wire to the grounding point.

## (STEP 6 cont.)

- **Complete the power connection.** Attach the barrel end of the included power supply to the booster.
- **Restore power and test.** Turn the 12V power back on by switching on the main 12V power or reconnecting the RV to shore power and battery. Use a multimeter to confirm the correct voltage (12V) at the booster unit (optional). Turn on the booster and check the indicator lights to ensure it's operating correctly.

**Additional tips.** Consult the RV Manual: Always refer to your RV's manual for specific information on the electrical system. If you're not comfortable working with electrical systems, consider seeking help from a professional RV technician.

## Booster Light Patterns

### SOLID GREEN

This indicates your weBoost Drive Reach is functioning properly and there are no issues with installation.

### SOLID RED

Band has shutoff. This is due to a feedback loop condition called oscillation. This is a built in safety feature that causes a band to shut off to prevent harmful interference with a nearby cell tower. Refer to Troubleshooting section.

### BLINKING RED, THEN SOLID GREEN

This indicates that one or more of the booster bands has reduced power due to a minor feedback loop condition called oscillation. This is a built in safety feature to prevent harmful interference with a nearby cell tower. If you are already experiencing the desired signal boost, then no further adjustments are necessary. If you are not experiencing the desired boost in coverage then refer to the Troubleshooting section.

### LIGHT OFF

If the Drive Reach signal booster's light is off, verify your power supply has power.



## (Booster Light Patterns cont.)

NOTE: The signal booster can be reset by disconnecting and reconnecting the power supply.

After troubleshooting, you must initiate a new power cycle by disconnecting and then reconnecting power to the booster.

## Troubleshooting

### FIXING BLINKING OR RED LIGHT ISSUES

**This section is only applicable if the light on the booster is red or blinking red and you are not experiencing the desired signal boost.**

- 1 Unplug the booster's power supply.
- 2 Relocate the inside and outside antenna further from each other. The objective is to increase the separation distance between them, so that they will not create this feedback condition discussed before.
- 3 Plug power supply back in and ensure switch is in ON position.
- 4 Monitor the indicator light on your booster. If, after a few seconds of 'power on', a solid or blinking red light appears, repeat steps 1 through 3. Increase the separation distance until the condition is corrected and/or desired coverage area is achieved.  
Note: Horizontal separation of the two antennas typically requires a shorter separation distance than vertical separation.

If you are having any difficulties while testing or installing your booster, contact our weBoost Customer Support team for assistance (1-866-294-1660).

## (Troubleshooting cont.)

### FREQUENTLY ASKED QUESTIONS

#### **How can I contact customer support?**

Customer Support can be reached Monday through Friday by calling 1-866-294-1660, or through our support site at [support.weboost.com](https://support.weboost.com).

#### **Why do I need to create distance between the outside antenna and inside antenna?**

Antennas connected to a booster create spheres of signal. When these spheres overlap, a condition called oscillation occurs. Oscillation can be thought of as noise, which causes the booster to scale down its power or shut down to prevent damage. The best way to keep these spheres of signal from overlapping is to maximize separation between the inside and outside antennas.

---

 1-866-294-1660

 [www.weboost.com](https://www.weboost.com)

 [support@weboost.com](mailto:support@weboost.com)

---

## Safety Guidelines

Use only the power supply provided in this package. Use of a non-weBoost product may damage your equipment.

Connecting this signal booster directly to the cell phone with use of an adapter will damage the cell phone.

RF Safety Warning: Any antenna used with this device must be located at least 8 inches (20 cm) from all persons.

AWS Warning: The Outside Antenna must be installed no higher than 31 feet 9 inches (10 meters) above ground.

### **This is a CONSUMER device.**

---

**BEFORE USE**, you **MUST REGISTER THIS DEVICE** with your wireless provider and have your provider's consent. Most wireless providers consent to the use of signal boosters. Some providers may not consent to the use of this device on their network. If you are unsure, contact your provider.

In Canada, **BEFORE USE** you must meet all requirements set out in ISED CPC-2-1-05.

You **MUST** operate this device with approved antennas and cables as specified by the manufacturer. Antennas **MUST** be installed at least 20 cm (8 inches) from (i.e., **MUST NOT** be installed within 20 cm of) any person.

You **MUST** cease operating this device immediately if requested by the FCC (or ISED in Canada) or licensed wireless service provider.

**WARNING.** E911 location information may not be provided or may be inaccurate for calls served by using this device.

(Safety Guidelines cont.)

**FOR MORE INFORMATION ON REGISTERING YOUR SIGNAL BOOSTER WITH YOUR WIRELESS PROVIDER IN THE U.S., PLEASE GO TO THE LINK BELOW:**

<https://www.weboost.com/carrier-registration>

## Antenna Info

The following accessories are certified by the FCC to be used with the Drive Reach Booster.

This radio transmitter 4726A-460061 has been approved by Innovation, Science and Economic Development Canada to operate with the antenna types listed below, with the maximum gain indicated. Antenna types not included in this list that have a gain greater than the maximum gain indicated for any type listed are strictly prohibited for use with this device.

	BAND 12/17	BAND 13	BAND 5	BAND 4	BAND 25/2
Outside antenna maximum permissible antenna gain (dBi) 50Ω	1.2	1.2	1.1	0.8	0.4
Inside antenna maximum permissible antenna gain (dBi) 50Ω	2.1	2.6	3.20	2.1	2.7

# Specifications

Drive Reach Cell Signal Booster					
<b>Model</b>	460061				
<b>FCC</b>	PWO460061				
<b>IC</b>	4726A-460061				
Connectors	SMA-Female				
Antenna Impedance	50 Ohms				
Frequency	698-716 MHz, 728-756 MHz, 777-787 MHz, 824-894 MHz, 1850-1995 MHz, 1710-1755/2110-2155 MHz				
Power output for single cell phone (Uplink) dBm	<b>700 MHz B12/17</b> 25.4	<b>700 MHz B13</b> 25.6	<b>800 MHz B5</b> 25.6	<b>1700 MHz B4</b> 26.7	<b>1900 MHz B2</b> 26.9
Power output for single cell phone (Downlink) dBm	4.8	4.8	4.8	4.6	4.5
Noise Figure	5 dB (nominal)				
Isolation	> 90 dB				
Power Requirements	12V 1.8A				

Each Signal Booster is individually tested and factory set to ensure FCC compliance. The Signal Booster cannot be adjusted without factory reprogramming or disabling the hardware. The Signal Booster will amplify, but not alter incoming and outgoing signals in order to increase coverage of authorized frequency bands only. If the Signal Booster is not in use for five minutes, it will reduce gain until a signal is detected. If a detected signal is too high in a frequency band, or if the Signal Booster detects an oscillation, the Signal Booster will automatically turn the power off on that band. For a detected oscillation the Signal Booster will automatically resume normal operation after a minimum of 1 minute. After 5 (five) such automatic restarts, any problematic bands are permanently shut off until the Signal Booster has been manually restarted by momentarily removing power from the Signal Booster. Noise power, gain, and linearity are maintained by the Signal Booster's microprocessor.

The term "IC" before the radio certification number only signifies that Industry Canada technical specifications were met. This device complies with Part 15 of FCC rules. This device contains licence-exempt transmitter(s)/receiver(s) that comply with Innovation, Science and Economic Development Canada's licence-exempt RSS(s). Operation is subject to the following two conditions: (1) This device may not cause interference, and (2) This device must accept any interference, including interference that may cause undesired operation of the device. Changes or modifications not expressly approved by weBoost could void the authority to operate this equipment.

## ✔ 2 YEAR WARRANTY

weBoost Signal Boosters are warrantied for two (2) years against defects in workmanship and/or materials. Warranty cases may be resolved by returning the product directly to the reseller with a dated proof of purchase.

Signal Boosters may also be returned directly to the manufacturer at the consumer's expense, with a dated proof of purchase and a Returned Material Authorization (RMA) number supplied by weBoost. weBoost shall, at its option, either repair or replace the product.

This warranty does not apply to any Signal Boosters determined by weBoost to have been subjected to misuse, abuse, neglect, or mishandling that alters or damages physical or electronic properties.

Replacement products may include refurbished weBoost products that have been recertified to conform with product specifications.

RMA numbers may be obtained by contacting Customer Support.

**DISCLAIMER:** The information provided by weBoost is believed to be complete and accurate. However, no responsibility is assumed by weBoost for any business or personal losses arising from its use, or for any infringements of patents or other rights of third parties that may result from its use.









# we:boost



3301 East Deseret Drive, St. George, UT

 1-866-294-1660  [www.weboost.com](http://www.weboost.com)  [support@weboost.com](mailto:support@weboost.com)

Copyright © 2024 weBoost. All rights reserved. weBoost products covered by U.S. patent(s) and pending application(s)  
For patents go to: [weboost.com/us/patents](http://weboost.com/us/patents)

NOT AFFILIATED WITH WILSON ANTENNA

GDE000603\_001\_06.24.24